

ESM 150 – Flat shoe milling device for all Rieter 60" cards

The seatings of the synthetic flat shoes of the aluminum flat bars have to be re-milled/replaced from time to time since they are subject to wear and run-in to varying degrees. Graf offers a compact and simple machine for this purpose. Independent and precise single-step milling of the flat shoes of all Rieter 60" cards from C60 to C80 cards.



Technical data

- Length: 1'990 mm
- Width: 490 mm
- Height: 450 mm
- Weight: 210 kg
- Power supply: 220 V / 400 V

Product details

- By reworking the flat shoes in a single clamping step of the flats, the shoes can be restored very accurately and rapidly
- The flat shoe milling device is compact and space-saving
- CE conformity

Customer advantages

- Milling flat of shoes with single-step clamping of the flat bar
- The setting behavior of the flats is significantly improved thanks to the milling
- Low capital costs
- Easy operation
- Compact, slim machine

ESM 150 – Flat shoe milling device for all Rieter 60" cards

Basic equipment

Item No 003041584

- Fully equipped ESM 150 with milling cutters for C60/C70/C72/C75 or C80
- Various mounting tools

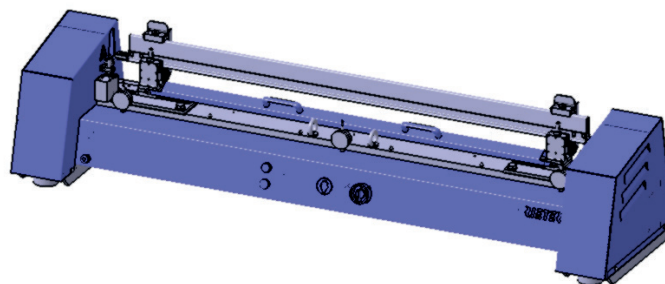

Additional equipment, card specific

Milling cutters for C60/C70/C72/C75

Item No 25179048

- Needed if the customer also has card C80 (milling cutters for C80 is included in the basic equipment)

Milling cutters for C80

Item No 25179044

- Needed if the customer has also card C60/C70/C72/C75 (milling cutters for C60/C70/C72/C75 is included in the basic equipment)

Optional

Working table for ESM 150

Item No 00Z02408

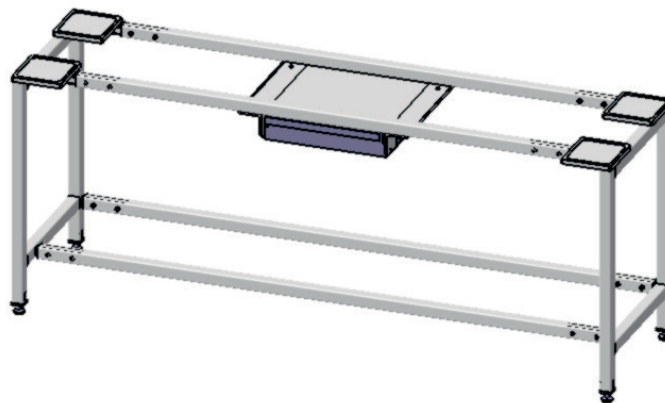

Please indicate power supply and exact card type when you order



Graf + Cie AG · Bildaustasse 6 · 8640 Rapperswil · Switzerland · Phone +41 55 221 71 11 · Fax +41 55 221 72 33 · info@graf-companies.com

www.graf-companies.com

 Premium Swiss Quality

