

Spinning preparation

Single-head draw frames (R)SB-D 55 and double-head draw frames (R)SB-D 27

RIETER

Rieter Draw Frames

Single-head draw frames (R)SB-D 55

Double-head draw frames (R)SB-D 27

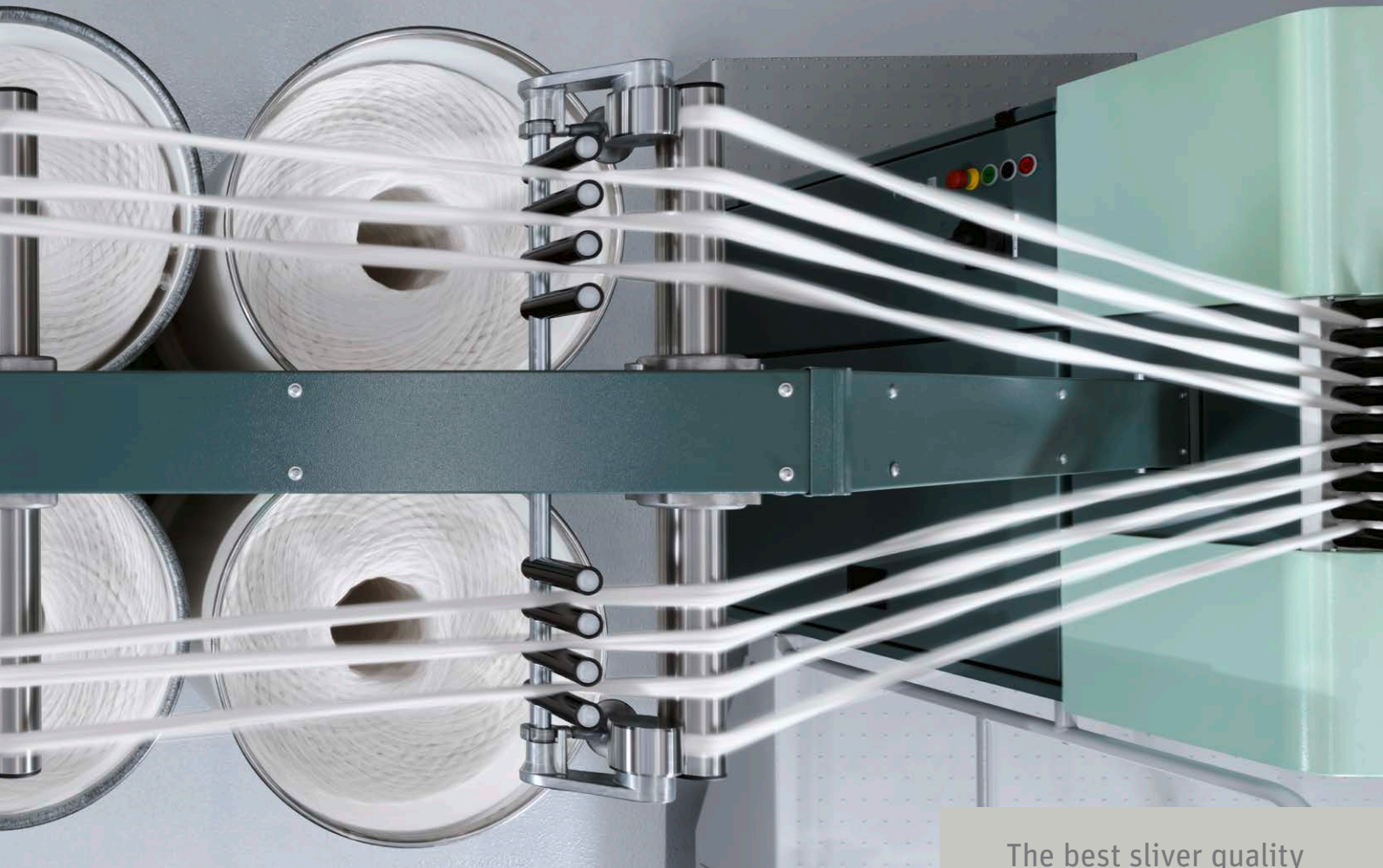

The best sliver quality
at highest productivity

A photograph of a textile factory. In the foreground, several large spools of white yarn are arranged in a row on a machine. The yarn is thick and has a distinct ribbed texture. The background shows industrial machinery, including rollers and pipes, with a green-painted section on the right. The lighting is bright, highlighting the white color of the yarn.

Best Quality
at Highest
Productivity



(R)SB-D 55

(R)SB-D 27

The latest generation of draw frames enables spinning mills to achieve the highest quality at a delivery speed of up to 1 200 m/min.

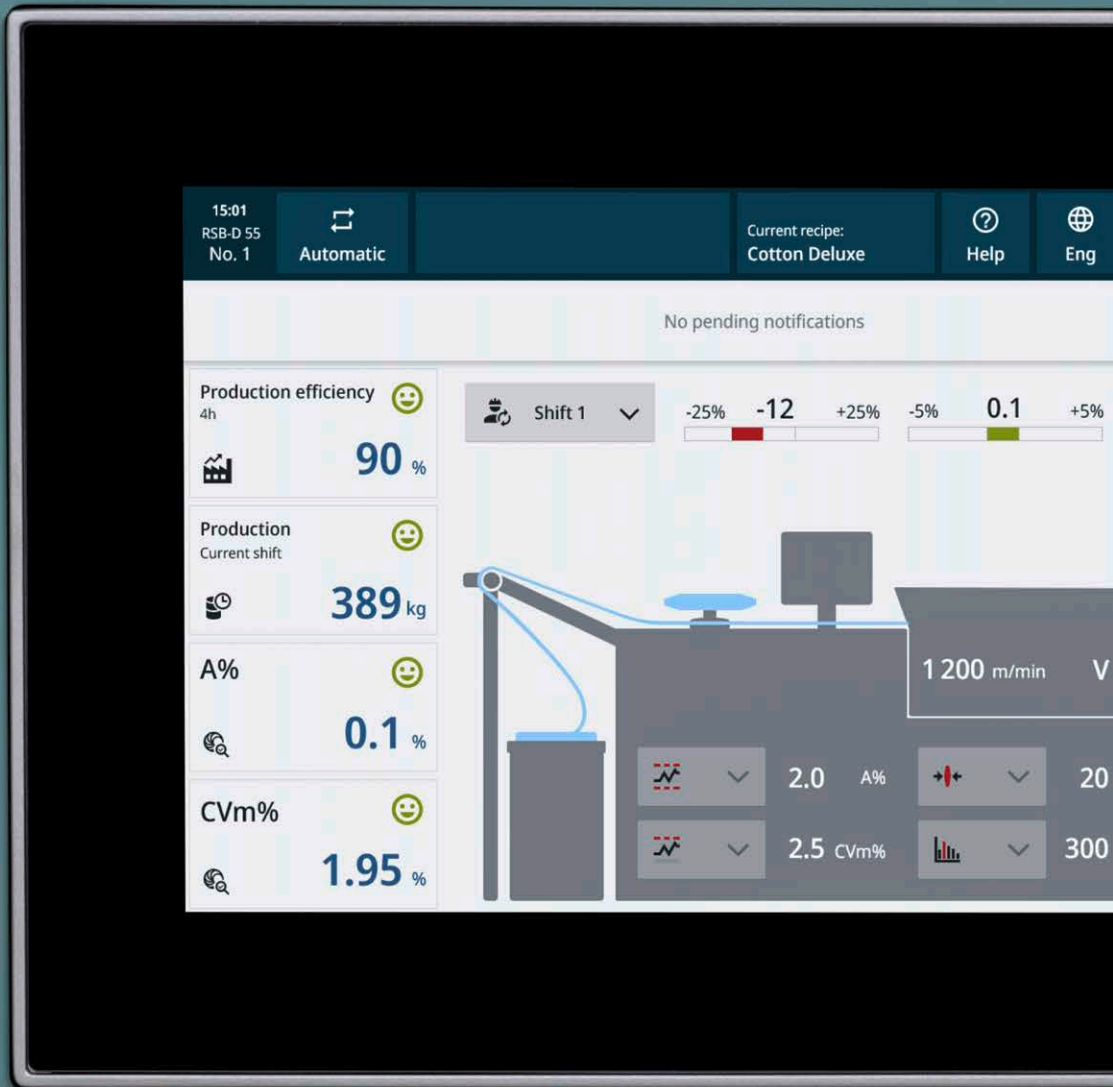

The further improved expert system SLIVERprofessional offers technological support and setting recommendations – also for processing recycled fibers.

Integrated Know-How

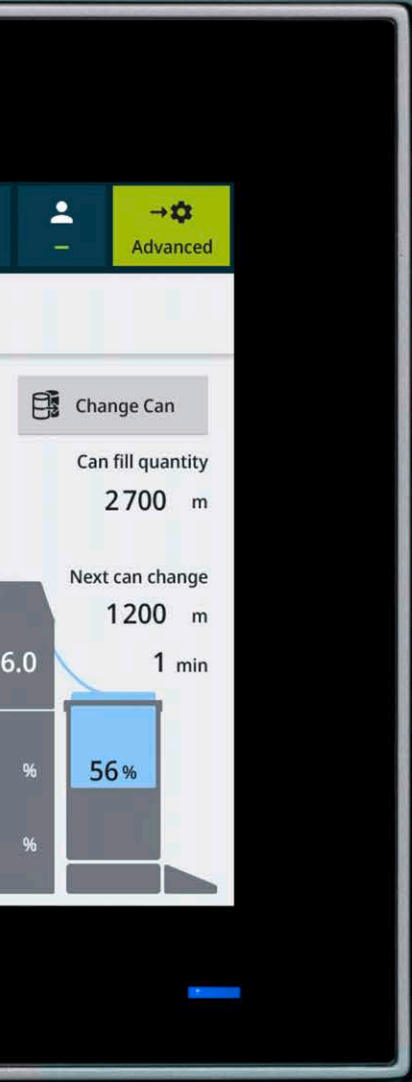

(R)SB-D 55

(R)SB-D 27

(R)SB-D 55

With the portfolio of autoleveler and non-autoleveler single- and double-head draw frames, Rieter offers a solution for diverse needs.

Broad Draw Frame Portfolio

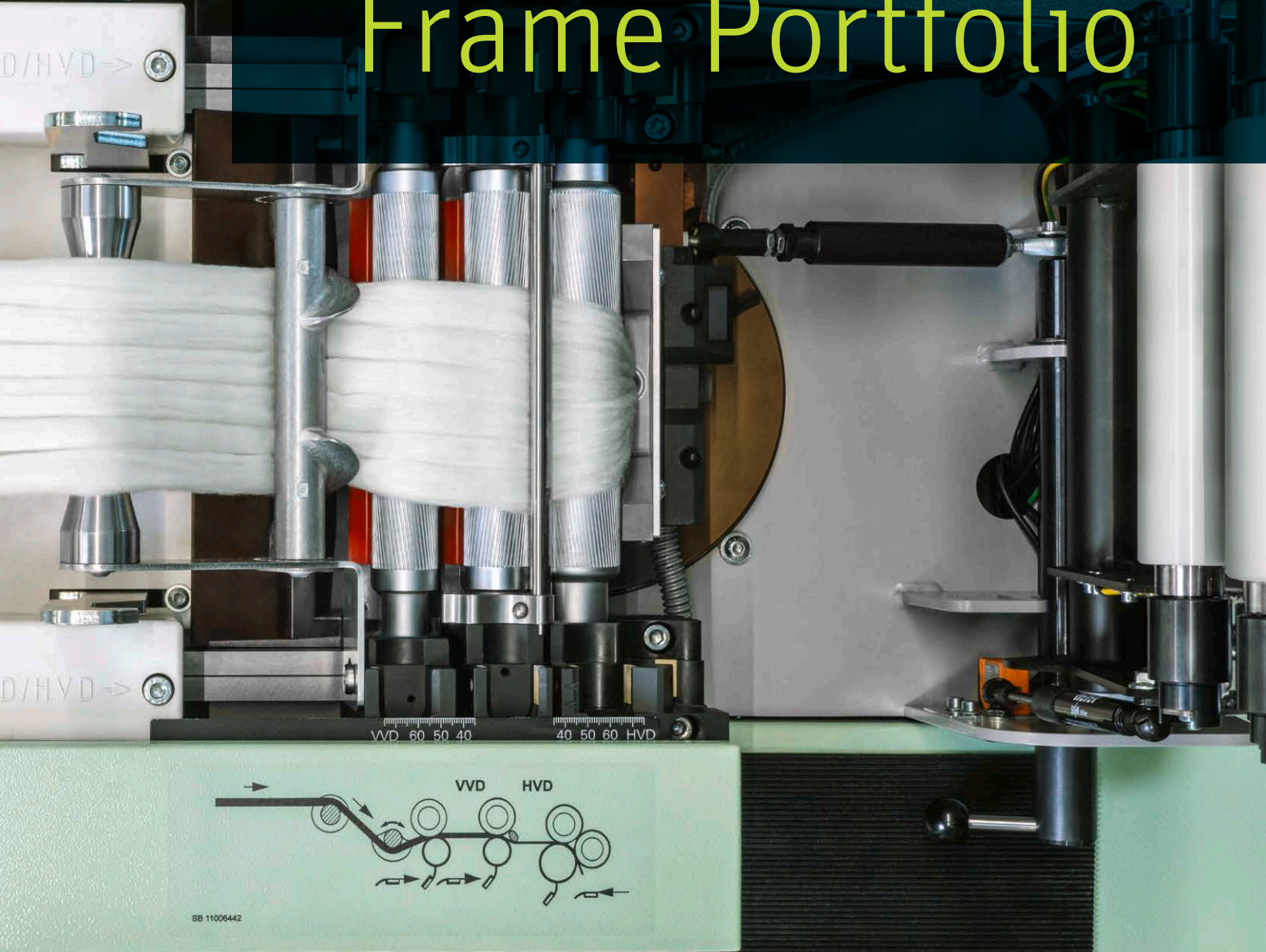

(R)SB-D 27

OUTSTANDING ADVANTAGES

Efficient Suction

Lifting cleaning lips on top rollers;
new suction nozzle for calender roller;
regulated drive

SB-D 55

SB-D 27



SLIVERprofessional

Enhanced expert system provides
know-how by additional setting
recommendations, also
for recycled fibers

Efficient Operator Guidance

Large 10" touch screen for easier
navigation and automatic guidance;
LEDs visible from a distance;
USB interface;
geometry with improved force direction;
central sliver guidance

Wide Draw Frame Portfolio

The right draw frame for every requirement;
machine layouts for minimum space requirements

Unique Sliver Coiling

Individual drive for the coiler;
sliver sensor for exact first sliver coils;
coiler control CLEANtube to prevent trash accumulations

RSB-D 27



RSB-D 55

High Productivity

Delivery speed of up to
1 200 m/min at best quality;
high efficiency thanks to new
coiler jam straightener

Modern Drafting System

New top roller bearings;
drafting geometry with
improved force direction;
central sliver guidance

Low Maintenance & Energy Costs

Wear inserts in cylinder bearing saddles;
new stronger power creel design;
energy-efficient drive concept ECOrized

Tailored Solutions for Every Need

Portfolio deep dive

Autoleveler draw frames and draw frames without autoleveling

Rieter offers a range of innovative and versatile solutions for the spinning mill. The cutting-edge draw frames provide spinners with a competitive advantage in terms of quality, productivity, flexibility, and space utilization while meeting their individual requirements.

The draw frames come as autoleveler (RSB-D 55 and RSB-D 27) and draw frames without autoleveling (SB-D 55 and SB-D 27) to match different demands. Rieter draw frames can operate at speeds of up to 1200 meters per minute, delivering consistent and outstanding performance. The autoleveler models include advanced RSB leveling technology for excellent sliver evenness and a patented sliver sensor to ensure exceptional running properties in downstream processes and highest yarn and final product quality.

Single-head draw frames RSB-D 55 and SB-D 55

The single-head draw frames RSB-D 55 and SB-D 55 are the solutions for maximum flexibility. These models adapt effortlessly to different fiber materials, making them ideal for processing various fibers. Innovative solutions keep the sliver strength constant and avoid sliver breaks which ensures highest downstream efficiency. The (R)SB-D 55 offers the highest sliver quality in the industry, ensuring spinners get the most out of the spinning process.

Double-head draw frames RSB-D 27 and SB-D 27

Rieter's double-head draw frames (R)SB-D 27 are designed to deliver maximum production output in minimal space. They boast low energy consumption, making them cost-effective and environmentally friendly. The completely independent heads of the RSB-D 27 feature outstanding sliver and yarn quality. The SB-D 27 model comes with a unique can changer capable of handling can diameters of up to 1 200 mm, ensuring the highest machine utilization. The three-row can arrangement allows spinners to get the best out of the available space.

Best-in Class Productivity

High delivery speeds at consistent quality

Best quality

Rieter's draw frames produce at delivery speeds of up to 1 200 m/min – depending on the fiber material – ensuring consistently high sliver quality. The reasons are numerous:

- Excellent scanning precision by means of small scanning disc (RSB)
- Leveling motor with highest dynamics (RSB)
- Best in class fiber guiding
- Precise sliver coiling due to the coiler CLEANcoil (and for 100% PES the coiler CLEANcoil-PES), inverter driven coiler drive and sliver sensor
- Prevention of faulty sliver due to the Rieter Quality Monitor (RQM) (standard on the RSB-D 27/55, optionally available on the SB-D 55)

Efficiency at the highest level

Production efficiency also lies at a high level. The following factors are some that are responsible for this:

- Low maintenance and cleaning requirements
- Enhanced expert system SLIVERprofessional for rapid assortment changeover
- Fewer lappings thanks to the large top rollers and lifting cleaning lips
- Reliable rotational can changer with short changeover times (linear can changer at the RSB-D 27)
- Two independent machine sides – if one side stops the other one continues to run at the RSB-D 27



Low Energy Consumption

Drive concept

Energy-saving drive concept

With the patented drive concept ECOrized, two servo-motors (RSB) drive the drafting system. The frequency-controlled drive for the suction and the individual drive for the coiler are unique. The drive solution for the coiler leads to straight belt tracking and a far longer lifetime of the belt.

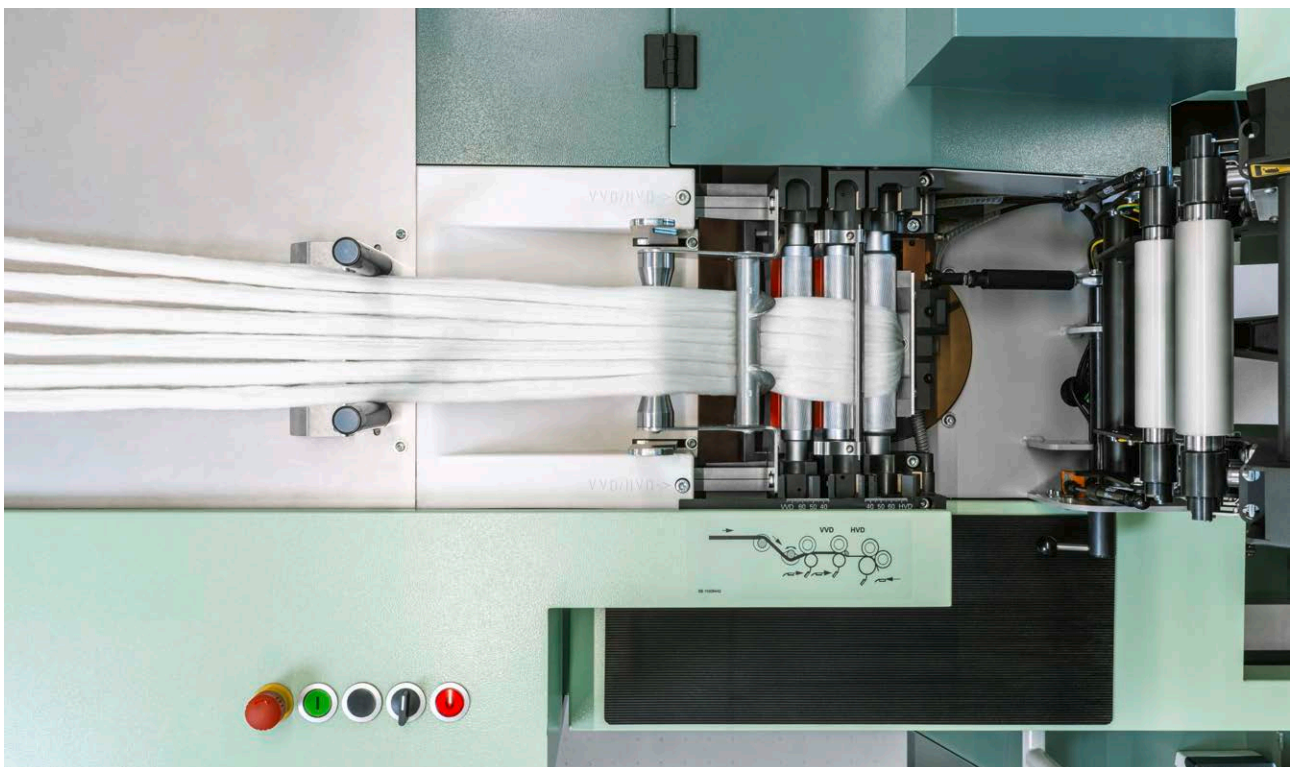

Power saving

The drive solution generates yearly savings. If the saving over the lifetime of the machine is compared to the investment, a very attractive ratio results. The Rieter draw frames are equipped with integrated energy measuring. This supports preventive maintenance and can reduce the risk of machine failures.

Sturdy in case of power fluctuations

With a short power fluctuation, the control voltage is supplied from the drive converter. This energy store can compensate short-term voltage interruptions and reductions – the draw frames keep running. With longer interruptions, the draw frames with active autoleveling (RSB) shut down in a controlled manner. The web remains in the threaded condition and allows a rapid restart.

Efficient Suction

Consistent yarn quality

Newly expanded suction optimized for recycled fibers

The newly expanded suction ensures greatest possible cleanliness, even in the calender area. This results in longer cleaning cycles and fewer thick places. When recycled fibers are processed, 4-fold doubling can be supportive. Here, a special web nozzle improves web guiding and guarantees fault-free operation with a high short-fiber content.

High sliver quality

Trash accumulations on the cleaning lips are drawn directly into the suction through the intermittent lifting of the lips. Practical tests confirmed that fewer sliver funnel blockages due to dust accumulation on the pressure bar occurred. The increased yarn cleanliness is shown in reduced IPI and Classimat faults as well as in a lower number of yarn clearer cuts.

Easier to clean

The patented cleaning lips and their layout reduce formation of deposits on the top rollers of the drafting system and consequently the associated cleaning procedures. Also with the processing of cotton containing honeydew, the cleaning lips have a positive effect. Fewer stops due to cleaning work and fewer laps in the drafting system increase the productivity of the machine.



Easy parameter setting

On the Rieter draw frames, the operator sets the suction intensity effortlessly and rapidly on the machine display. The setting is easy to reproduce. This simplifies not only material change but also eliminates quality deviations when, for instance, several draw frames are feeding sliver to one assortment.

Automatic filter cleaning

The automatic filter cleaning system keeps the filter screen clean with the help of a wiper. An innovative measurement of differential pressure in the suction box controls the automatic cleaning cycle and keeps the vacuum absolutely constant. The result is consistent sliver and yarn quality as well as running performance in the subsequent process.

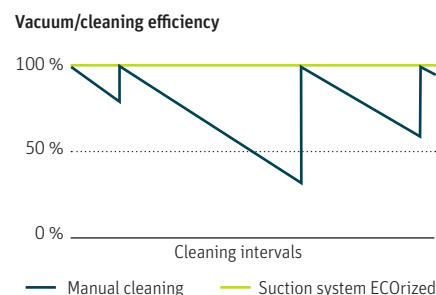
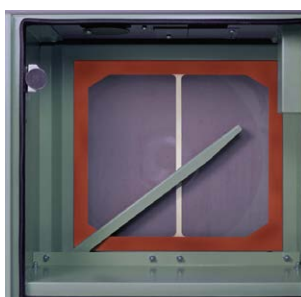

Sliver Guidance and Drafting

Modern drafting system

Innovative drafting system engineering

Rieter has further improved the drafting system. The new force transmission optimizes the load on the outlet cylinder. This results in less stress on the top rollers and improved fiber guidance towards the web funnel. The large top rollers guarantee interruption-free operation without lap formation as well as high service lives. They keep the rotational speed and consequently the temperature of the top roller cots low. This is the basis for high delivery speeds. The load of the top rollers can be set variably, the top roller bearings received a completely new design and are lifetime lubricated. Wear inserts in drafting system cylinder saddles keep drafting system robust.



Top rollers with optimized load distribution

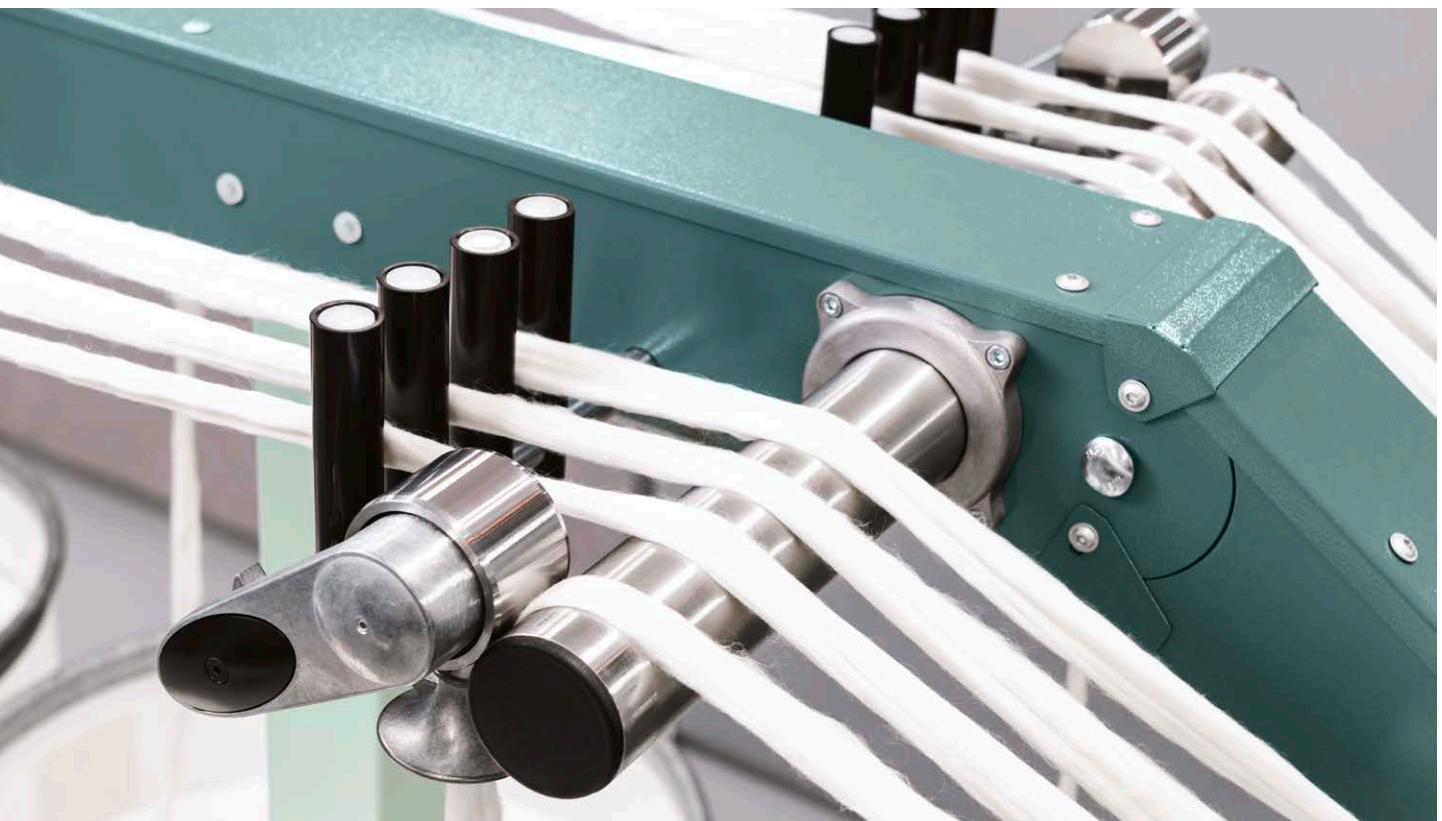

Proven fiber guidance

Conventional sliver guides in front of the drafting unit are often wrongly adjusted. The most frequent fault is non-central guidance of the sliver. The patented sliver guide guarantees central sliver guidance and consistent sliver quality at all times. The web width is reproducibly set by simple turning of the guide elements.

The geometry of the 4-over-3 drafting system allows close cylinder spacing and therefore also good processing of short fiber lengths. Additional fiber guides in the main drafting field prevent lateral slipping of the edge fibers. Fewer disturbing faults in the yarn in case of processing pure combed cotton are the result.

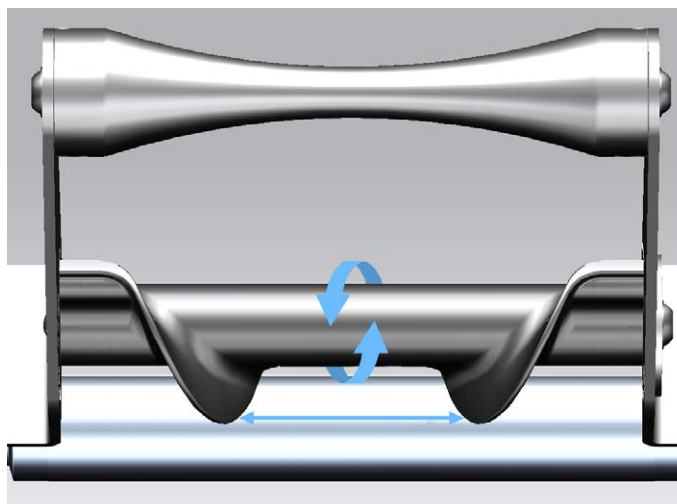

Centric sliver guide for consistent sliver quality (patented)

Easy operation

If a lap occurs in the drafting system, the rapid discharge already during the stopping of the machine prevents formation of hard laps. Easy removal of laps ensures the quality of the cots and therefore the running behavior of the draw frame. Threading a sliver into the web nozzle is very easy. The motors of the drafting system produce a finer sliver peak which is automatically threaded in by compressed air, quickly and reliably. The central setting of the drafting system distances without gauges allows rapid assortment change.

Precise Coiling

Consistent coiling quality and good downstream processing

CLEANcoil and CLEANcoil-PES coilers

CLEANcoil is the standard coiler for all fiber materials and therefore offers maximal flexibility. The spiral coiling tube ensures coiling which is free of drafting faults, even at high delivery speeds. A honeycomb structure on the coiler underside reliably prevents deposits.

For the processing of 100% polyester or recycled polyester, the CLEANcoil-PES with a different type of coating offers unique advantages in coiling. Even with critical polyester fibers, the cleaning cycle can be extended by at least 100%. This also leads to more consistent sliver and yarn quality. In addition, the CLEANcoil-PES deposits slivers with a blend content of 40% recycled polyester and more without any problems.

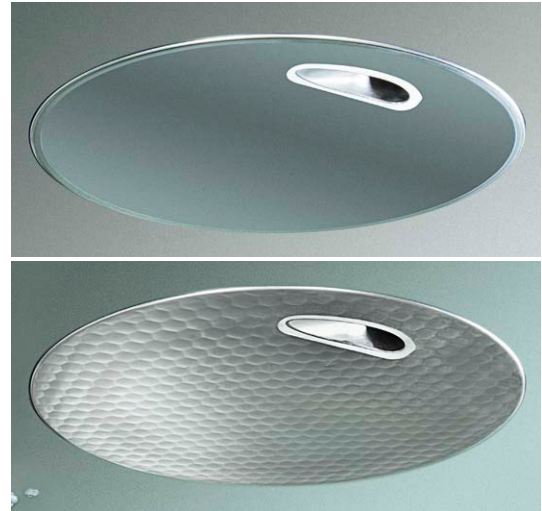

CLEANtube – coiling without trash accumulations

With the processing of cotton or its blends with man-made fibers, trash particles as well as short fibers can accumulate during can filling in the sliver duct of the coiler. When the can filling quantity is reached, the draw frame stops and this accumulation, known amongst experts as “mouse”, comes to rest on the top sliver layer.

The optional equipment CLEANtube is an intelligent control of the coiler drive, that prevents trash particles and short fibers accumulating in the sliver tube. Per year and draw frame head, CLEANtube saves up to 300 hours of work for the manual removal of the “mouse” as well as up to approximately 0.6% sliver waste. CLEANtube avoids up to 200 000 defective places per year and draw frame head and thus keeps the production efficiency in subsequent processing as well as the yarn quality high.



Fewer sliver breaks – higher roving frame efficiency

The new autoleveler draw frames RSB-D 55/27 offer a solution to avoid blockages in the coiler tube. These effects can occur, for example, in the event of fluctuations in ambient climate or during the processing of bulky materials and can lead to production interruptions. Previous measures, such as a larger coiler tube or a higher coiler speed, lead to reductions in sliver quality and thus yarn quality.

The unique coiler jam straightener for the RSB-D 55/27 uses the single-motor-driven coiler to eliminate possible sliver jams. This reduces operating effort and avoids sliver breaks in the draw frame, thus keeping the efficiency high at the autoleveler draw frame and in the downstream process. The last point is becoming increasingly important, especially for roving frames with more and more spinning positions, as every roving frame stop avoided means higher production efficiency in the downstream process.

Unique sensor for exact first sliver coils

A contact-free precision light barrier detects when the first sliver coils contact the coiler and only then switches the machine from the slow mode to full production speed. This guarantees controlled sliver coiling even in cans where the plates are too low and ensures consistent sliver and yarn quality. Precise sliver coiling from the first meter prevents tangles in the subsequent process and breaks when drawing the sliver out of the can. The cans therefore run without interruption until they are completely empty. This maintains machine efficiency at a high level, reduces operator intervention and eliminates sliver waste.



Quality without outliers

Even when only a small number of can plates are too low in a spinning mill, the sliver sensor brings considerable advantages. Assuming 1% of cans are affected, then that means for each draw frame a figure of up to 2 000 cans per year. Thanks to the sliver sensor, faultless first sliver coils are guaranteed in all these cans – despite difficult conditions. This is a further step towards perfect quality without outliers. This solution is patented and exclusively available with Rieter.



Light barrier for controlled sliver coiling

Reliable sliver separation on the RSB

When processing fibers with high fiber-fiber friction, as is often the case with man-made fibers, active sliver separation is necessary for a trouble-free can change. To achieve this, the motors of the autoleveller drafting system create a thin place, which is transported below the coiler and deliberately breaks at can change.



Efficient Operator Guidance

A new dimension in operator-friendliness

Touch display for intuitive operating

Thanks to the convenient and large, colored 10-inch machine touch display with improved menu navigation, intuitive operation is provided.

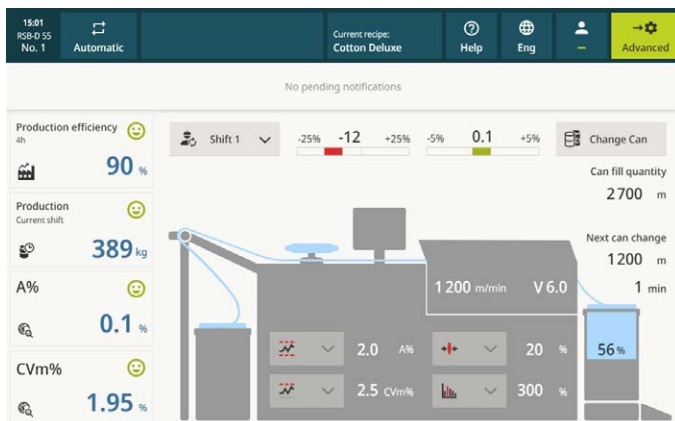

LED lights help the operator

Clear indications are of decisive importance for the operator when it concerns keeping distances short. Therefore, visible LEDs continue to indicate the condition of the draw frame. This enormously simplifies the work for the operator.



Versatile information

The display offers, in addition to data on production and sliver quality, helpful extra information: for example, the operating manual and a logbook for the complete documentation of the machine settings or detailed notification of machine downtimes with cause and duration. These are helpful tools for problem analysis on shifts with few personnel, for instance, at night.

Additionally, the energy monitoring system, displaying key metrics on its touchscreen, enables proactive preventive maintenance, optimizing performance and longevity.

Easy to operate and maintain

Rieter draw frames boast ergonomic advantages with large work platforms which ensure convenient and safe maintenance operations. Quick access to all machine components is facilitated by wide-opening hoods. The central lubricating strip or the optionally available single lubrication point enhance maintenance efficiency and prevent oversights of lubrication points.

Enhanced expert system SLIVERprofessional

The further improved expert system SLIVERprofessional is integrated into the machine display and offers valuable technological support. This unique tool offers setting recommendations – such as coiler and can plate speed, as well as sliver spread for the drafting system –, after entering the raw material data, for the entire machine. This can be transmitted as a data record onto the machine. In addition, SLIVERprofessional assists with the analysis of spectrogram faults such as periods and draft waves. This leads to a rapid fault correction and higher availability of the machine.

Now also ‘recycled fibers’ can be selected as an application.

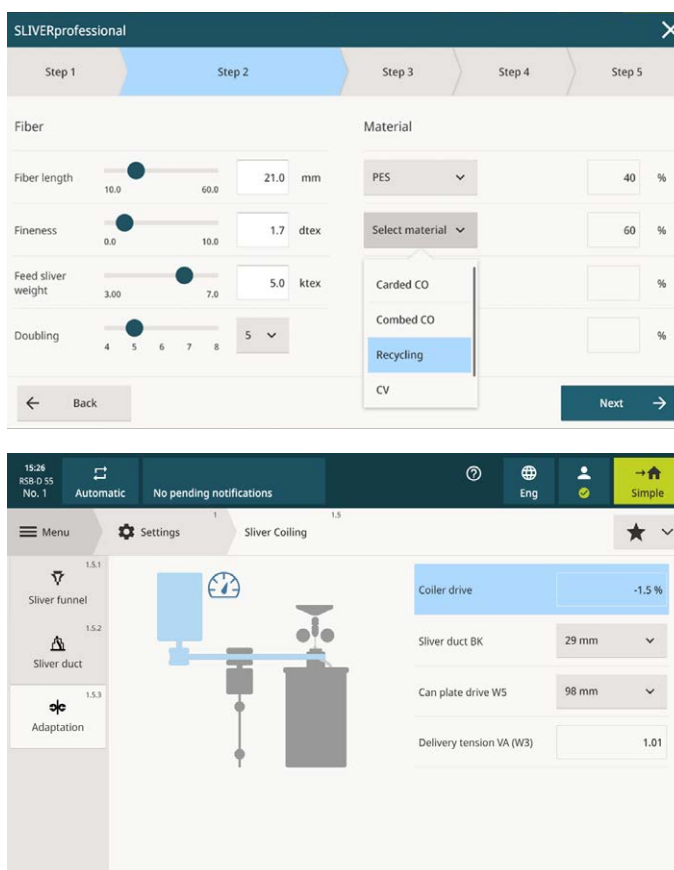

Highest Machine Availability

Sophisticated Service and Maintenance Concept

Long service life

The overpressure inside the machine pushes the heat outwards. This results in a long service life for the electronic and mechanical components. All essential fiber guiding parts have a resistant coating.

Rieter has further improved the drafting system. The new force transmission optimizes the load on the outlet cylinder. This results in less stress on the top rollers and improved fiber guidance towards the web funnel. Other innovations include life-time lubricated top roller bearings, drafting system cylinder saddles with wear inserts, active sliver infeed on all models, reinforced power creel rollers, and improved central suction. Rieter has significantly improved the robustness of the draw frame, ensuring stable operation at the highest level of quality and productivity.



Independent maintenance of machine sides for RSB-D 27

With Rieter's double-head draw frame RSB-D 27, both sides can be maintained independently of each other. This allows service tasks to be performed on one side of the machine, while the other side continues to produce, which improves the efficiency of the draw frame.

Modern interfaces for fast lot change

By means of the USB interface, setting data are quickly and easily transferred to other machines. The connection to the Rieter mill management system ESSENTIAL is a standard feature.

Self-setting autoleveling AUTOset for RSB-D 55 & 27

With a lot change, the leveling action point is the most important setting value of the autoleveling system. The self-setting autoleveling AUTOset determines the leveling action point automatically and thus saves valuable time. AUTOset guarantees the correct settings even with inexperienced personnel and ensures the high sliver quality level of the draw frames from Rieter.

Automatic setting of the levelling action point by means of AUTOset in approx. 1 minute

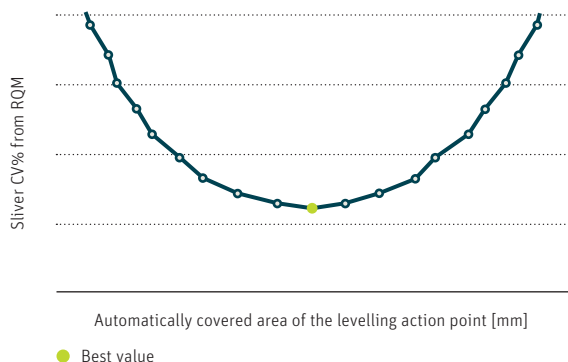

Quick tensioning device

Quick tensioning devices for the belts guarantee the right belt tension force, independent of maintenance personnel. This ensures a rapid belt change as well as a long lifetime of the belts and bearings.



Online Quality Monitoring

Reliability due to Rieter Quality Monitor



The Rieter Quality Monitor (RQM) – standard on the RSB-D 27 and RSB-D 55 and optionally available on the SB-D 55 – reliably prevents the production of faulty sliver. It operates independently of the autoleveling unit. The RQM continuously monitors the thickness of the delivered sliver by means of the moveable calender disc roll and stops the draw frame automatically if the pre-determined limits are exceeded. The spectrogram also visualizes shortest wave lengths and thus confirms the precision of the measurement. This reduces the number of sliver tests in the laboratory. For more advanced analyses, the connection to the mill management system ESSENTIAL is given.

Advantages of thick places detection

- Monitoring of the cleaning and maintenance services on the card, comber and draw frame
- Monitoring of the sliver piecings
- Support with technological optimizations
- Improvement of the sliver and yarn quality
- Securing high productivity on the roving frame, end spinning machine and winder

Quality data of the RQM

- Sliver count A%
- Sliver evenness CV% and length variation values for 5 cm, 10 cm, 25 cm, 50 cm, 1 m, 3 m, 5 m
- Actual spectrogram
- Presentation of the quality diagram up to 20 days
- Recording of thick places > 2 cm

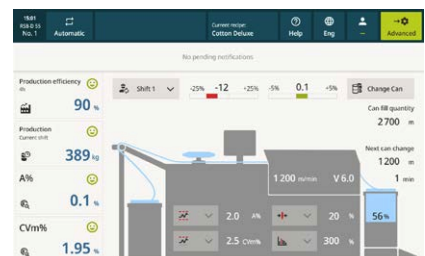
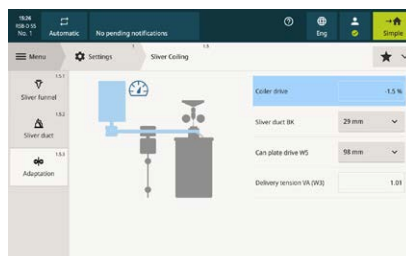
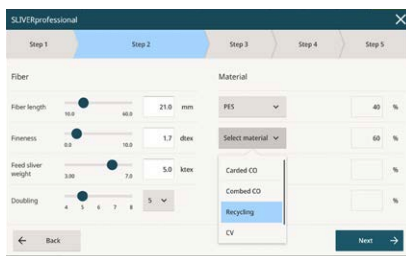

Outstanding Sliver Evenness with the RSBs

The RSB autoleveling with highest scanning precision and leveling dynamics

Leveling begins with scanning precision

Perfect leveling begins with the precision of the feed sliver scanning. In comparison to other “tongue and groove” systems, the RSB scanning is remarkable due to the smallest scanning rollers. Thus, a short piece of sliver is located between the rollers. This gives a high measurement resolution and is the prerequisite for exact leveling.



Leveling demands dynamics

The drive concept ensures that the precise scanning values are also transmitted right into the drafting system and improve the sliver quality. This requires a high dynamic level in the power transmission. This is achieved by means of fewer movable parts as well as a high dynamic level of the servomotors. This results in superb sliver evenness, even at highest delivery speeds – from the first to the last centimeter.

The RSB leveling principle

A digital signal processor processes the signals of the scanning discs on the basis of a sophisticated algorithmic calculation. The value is then precisely transmitted to the drive, when the measured sliver piece is found at the drafting point of the main drafting field. The result is a sliver resp. yarn with excellent short, middle and long-term evenness.

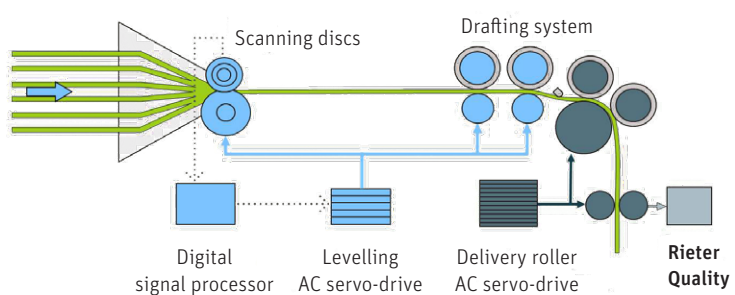

Minimal Space Requirements

Machine layouts for all space conditions

Sliver feed options

The draw frame feed is executed as actively driven roller feed, for:

- (R)SB-D 55/27: 2-row creels/6- to 8-fold doubling/
RSB-D 55/27 up to max. 12-fold doubling
- (R)SB-D 27: 2-, 3- and 4-row creels

The height of the supports is adjustable and can be adjusted to the respective can heights up to 1 520 mm.

Space requirements

The combination of the double-head draw frame SB-D 27 without autoleveler and the RSB-D 27 forms the most compact draw frame line on the market. Especially in limited spaces, this combination of machines is the first choice for a spinning mill.

To adjust to confined space conditions in the spinning mill with (R)SB-D 55, the following variations are available:

- Shortened spare can supply for short machine lengths
- Compact arrangement by joint platform with neighbouring draw frames for compact machine width

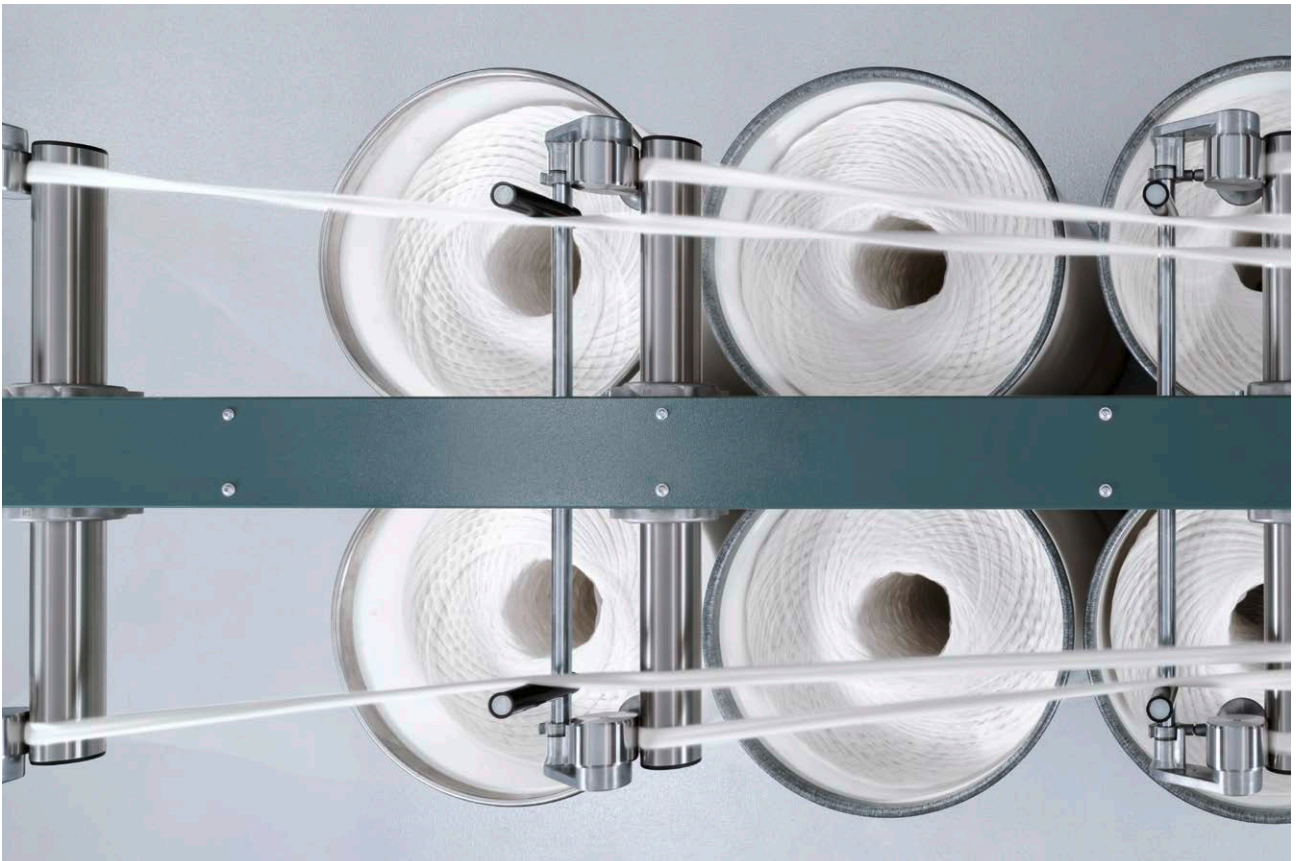

High Efficiency with the SB-D 27

Automatic can changer for cans up to 1 200 mm in diameter

Reliable rotational can changer

The rotational can changer changes the cans on both heads simultaneously. This ensures efficient operation of the draw frame and results in long run times without the operator having to intervene. A consistently high production rate is consequently guaranteed.

The Rieter can changer fills cans between 500 mm and 1 200 mm in diameter. When using cans with a diameter of 600 mm or less, a driven roller conveyor reliably feeds the cans to the changer.



43% more sliver in the can

Cans measuring 1 200 mm in diameter contain around 43% more sliver than cans that are 1 000 mm in diameter. With carded cotton, a can height of 1 200 mm equates to a filling weight of 76 kg; for cans with a height of 1 300 mm, the filling weight is an impressive 83 kg. With combed fiber material, filling quantities of up to 100 kg can be achieved.

Standstills significantly reduced

Larger can filling quantities reduce standstills and boost machine efficiency in the spinning mill preparatory work. This effect can be seen most clearly in the draw frame SB-D 27, where the bigger cans can be inserted both in the feed and in the coiler. The SB-D 27 is as much as 2.5% more efficient when using cans with a diameter of 1 200 mm than when using cans with a diameter of 1 000 mm.

Fewer transports, fewer operating personnel

Larger filling quantities reduce the number of can transports and can changes in the creels of the downstream machines by 30%. The cans can be easily moved on the floor of the spinning mill thanks to smooth-running rollers. This requires fewer operators.

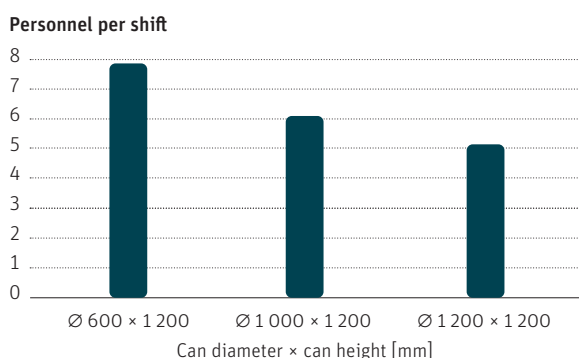

Fewer personnel thanks to larger cans – from the card to the autoleveler draw frame (basis for calculation: ring spinning mill with a daily output of 48 tons of combed cotton yarn)

An example calculation for a spinning mill with combed ring yarn and a production output of 48 tons a day shows the total personnel savings per shift for the carding line, the combing plant, the preliminary draw frame and the post draw frame. Using cans measuring 1 200 mm in diameter rather than 1 000 mm in diameter means that one operator less is required per shift – and using 1 200-mm cans instead of 600-mm cans requires almost three operators less per shift.

Increased quality thanks to fewer sliver piecers

In the example calculation, there are more than 370 000 fewer can transports a year with 1 200-mm cans than with 1 000-mm cans. This saves more than 370 000 sliver piecers and results in a correspondingly lower number of defects, which improves the yarn quality considerably.



Less waste

The sliver having a larger coiling radius in a 1 200 mm can optimizes the running performance at high drawing-off speeds, as with the combing preparation system OMEGAlap and highly productive draw frames. The cans run even better without interruption until they are completely empty.

Alternative with cans up to 1 500 mm in height

Alternatively, Rieter also offers filling systems for can formats measuring 1 000 mm in diameter and up to 1 500 mm in height. These cans hold around 25% more material than standard cans that are 1 200 mm in height.

Service Excellence

Throughout the whole life cycle of your spinning machines

To meet constantly growing market requirements, Rieter fundamentally redefined services and offers the most complete range of services on the market. From installation along the entire product life cycle, Rieter experts accompany customers on their road to success.

Excellence at every turn with Rieter's engineering solutions

The commitment to excellence drives Rieter to develop innovative solutions for spinning and winding, customized to meet unique customer needs. Rieter isn't just a supplier; they function as partners in fostering differentiation.

Maximizing your Rieter investment through the service support

Investing in Rieter machinery is a strategic decision. Rieter's dedicated service team ensures you maximize your investment throughout its entire life cycle, offering valuable resources such as training, consulting and performance optimization services.

Global presence, local support

With a global presence, spanning a repair services network comprising of 24 repair stations, Rieter is strategically located at the doorstep of its customers. The local repair services teams provide hands-on support for Rieter spinning and winding machines, no matter where your textile operations are based.

Seamless 24/7 ordering experience

In the fast-paced textile industry, time is money. Rieter's user-friendly webshop, ESSENTIALorder, offers a 24/7 personalized ordering experience, helping you optimize your stock levels with ease.



ESSENTIAL – Rieter Digital Spinning Suite

Rieter’s all-in-one mill management system

ESSENTIAL leverages digital technology for the textile value creation. The Rieter Digital Spinning Suite analyzes data of the entire spinning mill in real-time and provides meaningful key performance indicators based on this.

With comprehensive and clearly arranged digital analysis, the system supports management in strengthening the expertise of mill staff, eliminating inefficiencies and optimizing processes across the entire system. Through its holistic approach, ESSENTIAL connects the dots in the spinning mill.

ESSENTIAL is a modular system, so the spinning mill can be gradually digitized.

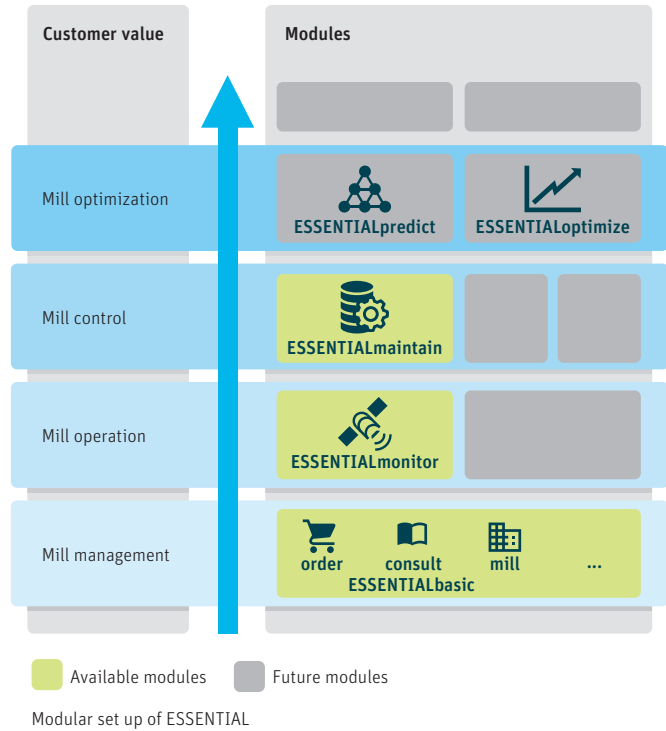

ESSENTIALbasic

ESSENTIALbasic, the starter module of the Rieter Digital Spinning Suite, is available free of charge to all Rieter customers. This module includes solutions such as the Rieter calculator, ESSENTIALorder and ESSENTIALconsult.

Each user, from mill owner to operator, gets an overview of the relevant information needed for their daily tasks.

Customer values:

- Making work organization smooth
- Strengthening staff expertise

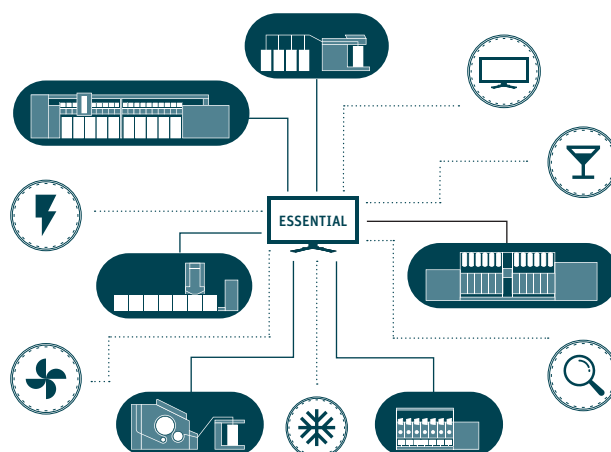

ESSENTIAL connects the entire spinning mill

ESSENTIALmonitor

ESSENTIALmonitor revolutionizes the spinning process by providing comprehensive data organization. With its advanced tracking capabilities, the system identifies process weaknesses and provides valuable insights to improve operational efficiency and cost-effectiveness.

Seamless integration of production, energy and quality data ensures fast response times and optimized spinning mill performance.

Customer values:

- Receiving improvement suggestions
- Optimizing machine operating hours with planned maintenance
- Enhancing machine productivity, output quality reduced energy consumption

ESSENTIALmaintain

ESSENTIALmaintain enables intelligent spinning mill maintenance. It analyzes sensor data from critical machine components and identifies deviations to avoid outages. This improves machine productivity and lengthens the service life while reducing the overall costs of inspection and maintenance.

From Rieter to third-party spinning equipment and auxiliaries, ESSENTIALmaintain covers the entire spinning mill maintenance needs.

Customer values:

- Maintaining machines' highest availability
- Identifying potential failure of equipment upfront
- Planning maintenance schedules

Machine Data

Autoleveler draw frame RSB-D 55 and draw frame without autoleveling SB-D 55

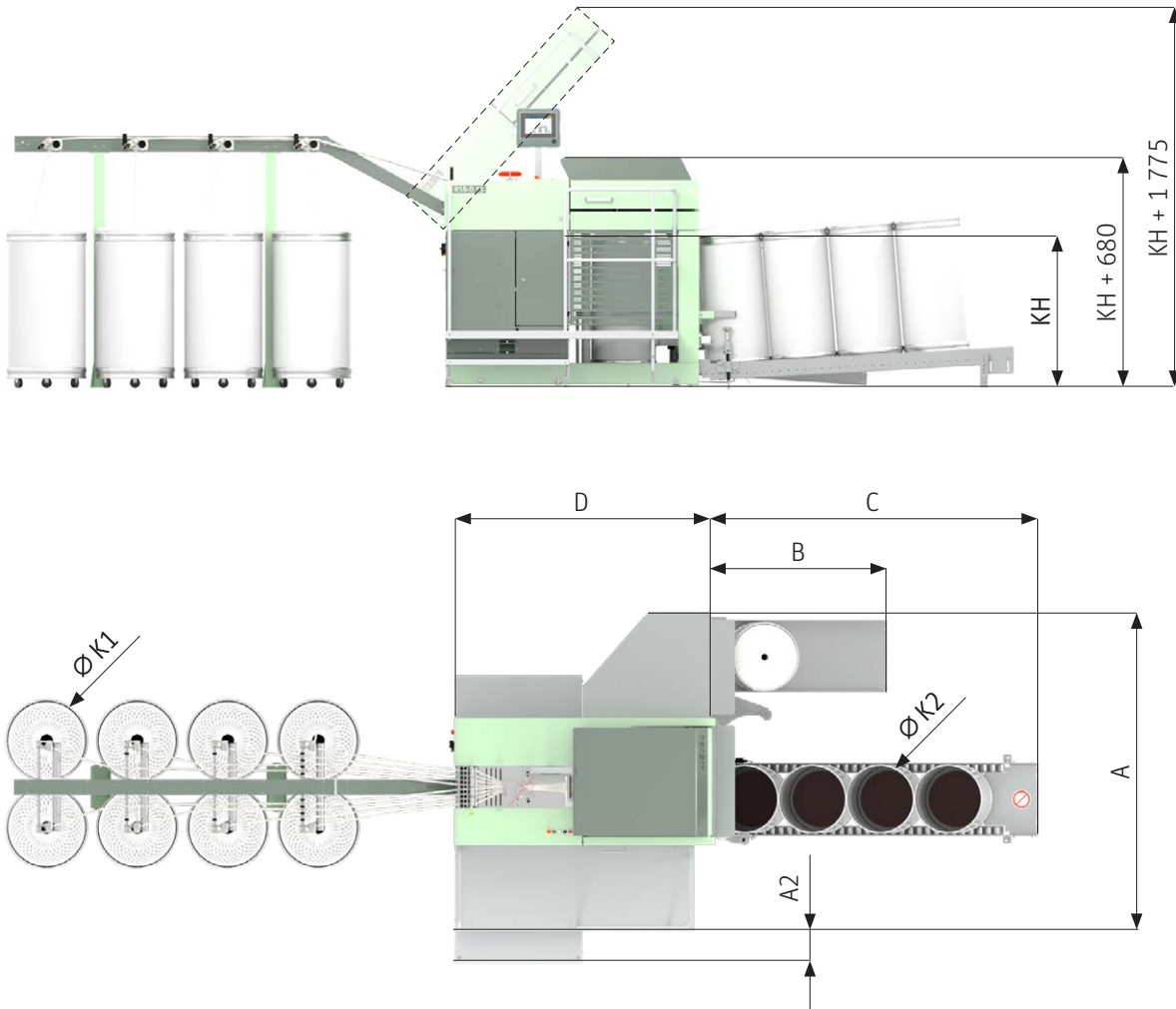

Coiling with can changer							
K2 [mm]	Number of empty cans	A [mm]	B [mm] ejected onto floor	B [mm] ejected onto trolley	C [mm] cans with castors	C [mm] cans without castors	D [mm]
300	5	2 380	1 300	1 200	2 720	1 840	1 960
350	5	2 380	1 300	1 400	3 105	2 225	1 960
400	5	2 380	1 300	1 600	3 302	2 425	1 960
450	4	2 380	1 300	1 800	3 105	2 225	1 960
470	4	2 380	1 300	1 880	3 105	2 225	1 960
500	4	2 380	1 300	2 000	3 305	2 422	1 960
600	4	2 380	1 406	2 540	3 360	2 280	1 960
1 000 (only SB)	1	2 935	940	—	2 430	—	1 960

Power creel (driven)			
K1 [mm]	L6 [mm]	L8 [mm]	L12 [mm] *
600	2 850	3 350	
1 000	3 700	4 750	6 850
1 200	4 200	5 460	

A2 dependent on the can height KH	
KH [mm]	A2 [mm]
900	0
≥1 000	236
≥1 150	478

* L12: Power creel 2-row 12-fold

Technological data			
Type	RSB-D 55	SB-D 55	RSB-D 55c
Material	Cotton, man-made fibres, blends, fibre length up to 60 mm		
Doubling [fold]	up to 12	up to 8	up to 12
Feed [ktex]	12 – 50	12 – 50	12 – 50
Draft [fold]	4.0 – 11.6	4.5 – 11.6	4.0 – 11.6
Delivered sliver weight [ktex]	1.25 – 7	1.25 – 7	1.25 – 7
Technical data			
Delivery	single	single	single
Delivery speed [m/min]	up to 1 200	up to 1 200	up to 600
Installed power	Main motor [kW]	3.90	3.90
	Intake motor [kW]	3.90	3.90
	Suction motor [kW]	1.50	1.50
	Machine control [kW]	0.50	0.26
	Coiler motor [kW]	1.10	1.10
	Can changer [kW]	0.25	0.25
Compressed air/consumption [m ³ /h] min. 6 bar	0.08	0.08	0.08

Standard equipment

- Coiler jam streightener
- Energy-saving drive concept ECOrized (patented)
- Max. delivery speed 1 200 m/min (RSB-D 55c: 600 m/min)
- Frequency-controlled drive for coiler, suction, drafting and delivery speed (SB-D 55: without drafting)
- Rieter spring-loaded 4 over 3 drafting system
- Drafting system suction unit with cleaning lips on top and bottom rollers
- Automatic filter cleaning
- Rapid top roller load relief in the event of stoppages or lap formation
- Central drafting system setting without gauges
- Pneumatic sliver threading-in with sliver refinement
- CLEANcoil coiler with honeycomb structure (standard)
- Sensor for sliver coiling
- Sliver separation by means of draw frame draft (only RSB)
- Automatic can changer
- Spare can supply for up to 5 reserve cans
- Highly dynamic levelling system with “tongue and groove” scanning rollers (RSB)
- Self-adjusting autolevelling AUTOset (RSB)
- Quality monitoring Rieter Quality Monitor RQM
- Central lubricating strip
- Lifetime lubricated top roller bearings
- Quick tensioning device for belts
- Machine display as touchscreen for intuitive operation
- Operating manual integrated in the machine display
- LED lights for operator guidance, visible from a distance
- USB interface
- Port to mill management system ESSENTIAL
- Operating manual on CD with videos for setting and maintenance

Variants

- Can format at feed unit: Ø up to 1 200 mm, height up to 1 520 mm
- Can format at delivery unit: Ø 300 – 1 000 mm (for RSB-D 55 up to 600mm), height up to 1 520 mm
- Can discharge onto floor or can trolley
- Power creel: 2-row can setup
- Doubling: 6-, 8- and 12-fold
- Bobbin creel (not driven): 2-row can setup
- Integrated suction (exhaust air into room or duct)
- Central suction
- Machine mountable on floor or recessed into floor

Options

- CLEANtube – sliver coiling without trash and short fibre deposits
- Coiler CLEANcoil-PES (100% PES)
- Central lubrication (central nipple)
- Shortened spare can supply (on consultation)
- Docking unit for can trolleys
- Connection platform for space-saving machine layout
- SLIVERprofessional expert system integrated in machine display
- Can brake for cans with castors (diameter 500, 600 mm)
- RQM for SB-D 55
- Sliver cohesion strenghtener for RSB

Machine Data

Double-head draw frame without autoleveling SB-D 27

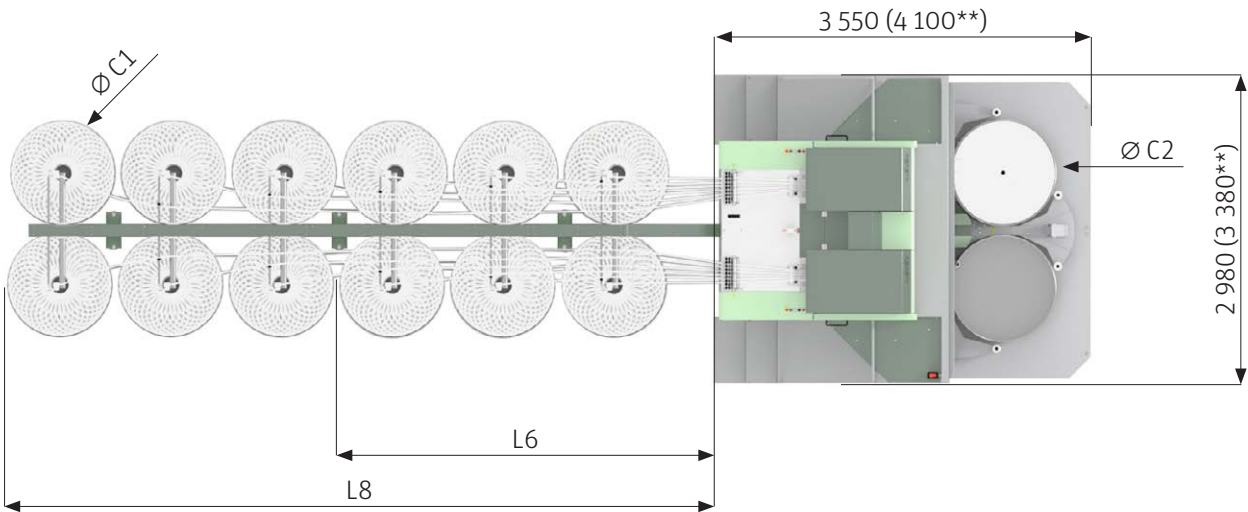

Power creel (driven)			
C1 [mm]	Feed variants [rows]	L6 [mm]	L8 [mm]
600	2	4 700	6 000
600	4	2 800	3 500
1 000	2	6 900	9 000
1 000	3	4 750	6 850
1 200	2	8 000	10 500
1 200	3	5 460	7 980

Delivery unit				
C2 [mm]	CH [mm]	Can changer	Layout	Empty cans [number]
500, 600	900 - 1 520	with	in or onto floor	2 per head
1 000	900 - 1 520	with	in or onto floor	1 per head
1 200	1 200, 1 300	with	in or onto floor	1 per head

* Only when mounted on the floor
 ** 1 200 mm can changer

Technical data		
Delivery	2	
Delivery speed [m/min]	up to 1 200	
Installed power	Main motor [kW]	8.50
	Suction motor [kW]	1.50
	Machine control [kW]	0.13
	Coiler motor [kW]	2.50
	Can plate motor [kW]	0.40
	Can changer [kW]	0.44
Compressed air/consumption [m ³ /h] min. 6 bar	0.10	

Standard equipment

- Energy-saving drive concept ECOrized (patented)
- Max. delivery speed 1 200 m/min
- Frequency-controlled drives for coiler, can plate, suction and delivery speed
- Rieter's spring-loaded 4-over-3 drafting system
- Drafting system suction with cleaning lips on top and bottom rollers
- Central drafting system setting without gauges, simultaneous for both sides
- Rapid top roller load relief in the event of a standstill or lap formation
- Pneumatically-supported sliver threading
- Coiler CLEANcoil with honeycomb structure (standard)
- Automatic can changer
- Reliable sliver cutting without additional mechanism
- Automatic filter cleaning
- Central lubricating strip
- Lifetime-lubricated top roller bearings
- Touchscreen for intuitive operation
- Quick-tensioning device for belts
- Operating instructions integrated in the machine display
- LEDs for operator guidance, visible from a distance
- USB interface
- Operating instructions (digital)
- Connection port to mill management system ESSENTIAL

Technological data	
Machine	SB-D 27
Material	Cotton, man-made fibers, blends, fiber lengths up to 60 mm
Doubling [fold]	up to 8
Feed [ktex]	20 – 50
Draft [fold]	4.5 – 11.6
Delivered sliver weight [ktex]	2.5 – 7.0

Variants

- Can format at feed: diameter up to 1 200 mm, height up to 1 520 mm
- Can format at delivery: diameter 500, 600, 1 000 mm, 1 200 mm, height up to 1 520 mm
- Power creel: 2-, 3- and 4-row creel
- Integrated suction (exhaust air into room or duct)
- Central suction
- Machine mountable on floor or recessed into floor

Options

- Coiler CLEANcoil-PES (100% PES)
- CLEANtube – sliver coiling without trash and short fibre deposits
- SLIVERprofessional expert system integrated in machine display
- Sensor for sliver coiling
- Can brake for cans with castors (diameter 500, 600 mm)

Machine Data

Double-head autoleveler draw frame RSB-D 27

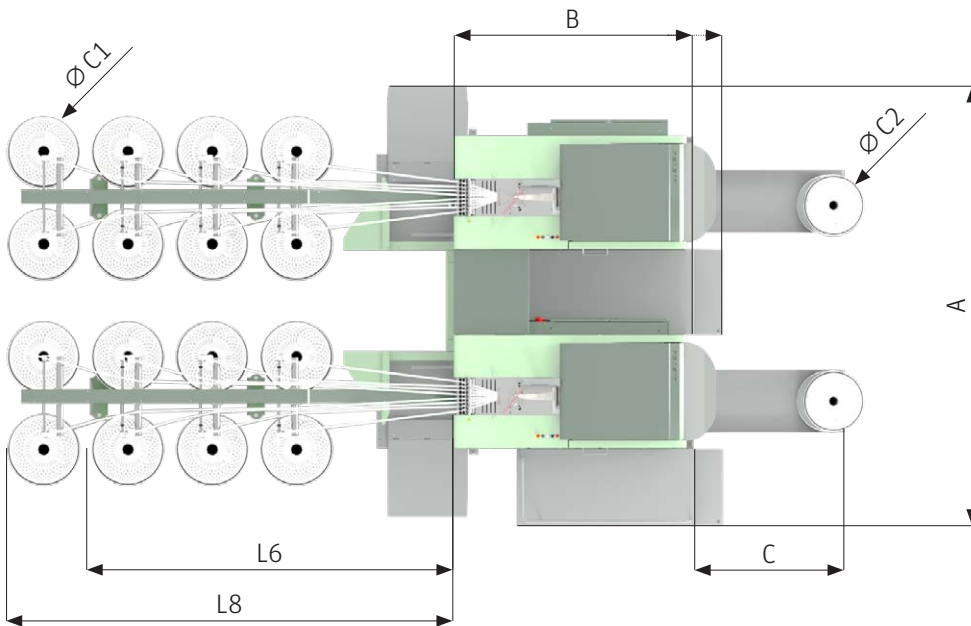
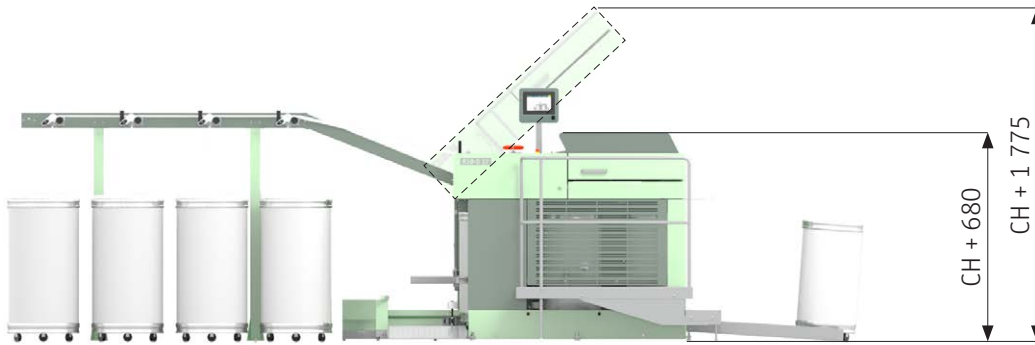

Power creel (driven)				
C1 [mm]	Feed variants [rows]	L6 [mm]	L8 [mm]	L12 [mm] *
600	2	5 000	6 300	
600	3	4 800	6 950	
600	4	3 000	3 700	
1 000	2	7 150	9 250	
1 000	3	5 000	7 150	9 300
1 200	2	8 250	10 750	
1 200	3	5 750	8 275	

* L12: Power creel 3-row 12-fold

Coiling with can changer		
CH [mm]	A [mm]	B [mm]
900	3 420	1 960
1 000 – 1 100	3 420	2 198
1 150 – 1 220	3 420	2 436
1 270 – 1 520	3 740	2 436

C2 [mm]	C [mm] Discharge onto floor without castors	C [mm] Discharge onto floor with castors
400 – 500	1 300	2 500
600	1 300	1 300

Technological data		
Type	RSB-D 27	RSB-D 27c
Material	Cotton, man-made fibers, blends, fiber lengths up to 60 mm	
Doubling [fold]	up to 12	up to 12
Feed [ktex]	12 – 50	12 – 50
Draft [fold]	4.0 – 11.6	4.5 – 11.6
Delivered sliver weight [ktex]	1.25 – 7	1.25 – 7

Technical data		
Delivery	2	2
Delivery speed [m/min]	up to 2 x 1 200	up to 2 x 600
Installed power	Main motor [kW]	2 x 3.90
	Feed motor [kW]	2 x 3.90
	Suction motor [kW]	1.50
	Machine control [kW]	0.50
	Coiler motor [kW]	2 x 1.10
	Can table motor [kW]	2 x 0.20 / 2 x 0.37
	Can changer [kW]	2 x 0.12
Compressed air/consumption [m ³ /h] min. 6 bar	2 x 0.05	2 x 0.05

Standard equipment

- Energy-saving drive concept ECOrized (patented)
- Max. delivery speed 2 x 1 200 m/min (RSB-D 26c: 2 x 600 m/min)
- Frequency-controlled drives for coiler, can plate, suction, draft and delivery speed
- Rieter's spring-loaded 4-over-3 drafting system
- Drafting system suction with cleaning lips on top and bottom rollers
- Automatic filter cleaning
- Rapid top roller load relief in the event of a standstill or lap formation
- Central drafting system setting without gauges
- Pneumatic web threading with sliver refinement
- Coiler CLEANcoil with honeycomb structure (standard)
- Sensor for sliver coiling
- Sliver cutter by means of draw frame draft
- Automatic can changer
- Empty can feed with two spare cans per head
- Highly dynamic autoleveler system with "tongue and groove" scanning discs
- Self-setting autoleveler AUTOset
- Quality monitoring Rieter Quality Monitor RQM
- Central lubricating strip
- Lifetime-lubricated top roller bearings
- Quick-tensioning device for belts
- Touchscreen for intuitive operation
- Operating instructions integrated in the machine display
- LEDs for operator guidance, visible from a distance
- USB interface
- Connection port to mill management system ESSENTIAL
- Operating instructions (digital)

Variants

- Can format at feed unit: diameter up to 1 200 mm, height up to 1 520 mm
- Can format at delivery unit: diameter 400 – 600 mm, height up to 1 520 mm
- Can discharge onto floor or can trolley
- Power creel: 2-, 3- and 4-row can setup
- Doubling: 6-, 8- and 12-fold
- Integrated suction (exhaust air into room or duct)
- Central suction
- Machine mountable on floor or recessed into floor

Options

- CLEANtube – sliver coiling without trash and short-fiber deposits
- Coiler CLEANcoil-PES (100% PES)
- Central lubrication (central nipple)
- Can magazine with three empty cans per head (for cans without castors)
- Docking unit for can trolleys
- Can brake for cans with castors
- SLIVERprofessional expert system integrated in machine display



Rieter Ltd.
Klosterstrasse 20
CH-8406 Winterthur
T +41 52 208 7171
machines@rieter.com
aftersales@rieter.com

Rieter India Private Ltd.
Gat No. 768/2, Village Wing
Shindewadi-Bhor Road
Taluka Khandala, District Satara
IN-Maharashtra 412 801
T +91 2169 664 141

**Rieter (China) Textile
Instruments Co., Ltd.**
390 West Hehai Road
Changzhou 213022, Jiangsu
P.R. China
T +86 519 8511 0675

www.rieter.com

The data and illustrations in this brochure and on the corresponding data carrier refer to the date of printing. Rieter reserves the right to make any necessary changes at any time and without special notice. Rieter systems and Rieter innovations are protected by patents.

3690-v2 en 2605